

- 1
- 2
- 3
- 4
- 5
- 6
- 7
- 8
- 9
- 10
- 11
- 12
- 13
- 14
- 15
- 16
- 17
- 18

STANDARDAUSFÜHRUNG

Rundprofil, ohne Montagebohrungen, sandgestrahlt, matt.
 - **GN 425.3-ST**: Stahl.
 - **GN 425.3-NI**: Edelstahl 1.4301.

MONTAGEHINWEIS

Schweißen.

FUNKTIONEN UND ANWENDUNGEN

D2-Bohrungen dienen bei Bedarf zur Aufnahme von Spann- oder Positionierstiften, die den Bügelgriff über die Ausrichtbohrungen im Gegenstück zum Anschweißen auf einfache Art positionieren und befestigen.

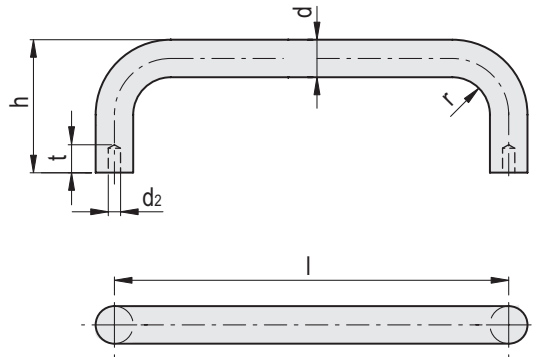
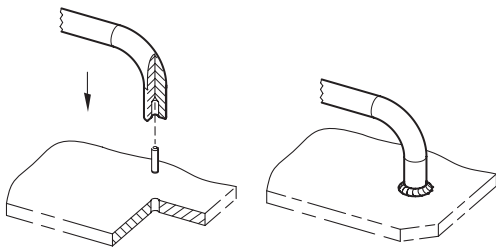

GN 425.3-ST

Code	Artikelnummer	d	l±0.5	d2 H12	h	r	t	Δ
GN.26903	GN 425.3-8-64-ST	8	64	3	35	10	5	45
GN.26905	GN 425.3-8-88-ST	8	88	3	35	10	5	55
GN.26907	GN 425.3-8-100-ST	8	100	3	35	10	5	60
GN.26909	GN 425.3-10-100-ST	10	100	3	43	12	5	113
GN.26724	GN 425.3-10-125-ST	10	125	3	43	12	5	110
GN.26726	GN 425.3-10-160-ST	10	160	3	43	12	5	130
GN.26734	GN 425.3-12-125-ST	12	125	4	51	14	6	170
GN.26736	GN 425.3-12-160-ST	12	160	4	51	14	6	210
GN.26738	GN 425.3-12-200-ST	12	200	4	51	14	6	245
GN.26713	GN 425.3-16-125-ST	16	125	4	59	18	6	320
GN.26715	GN 425.3-16-160-ST	16	160	4	59	18	6	370
GN.26717	GN 425.3-16-200-ST	16	200	4	59	18	6	440
GN.26719	GN 425.3-20-200-ST	20	200	5	68	22	8	700
GN.26721	GN 425.3-20-250-ST	20	250	5	68	22	8	830

GN 425.3-NI

Code	Artikelnummer	d	l±0.5	d2 H12	h	r	t	Δ
GN.26902	GN 425.3-8-64-NI	8	64	3	35	10	5	45
GN.26904	GN 425.3-8-88-NI	8	88	3	35	10	5	55
GN.26906	GN 425.3-8-100-NI	8	100	3	35	10	5	60
GN.26908	GN 425.3-10-100-NI	10	100	3	43	12	5	113
GN.26723	GN 425.3-10-125-NI	10	125	3	43	12	5	115
GN.26725	GN 425.3-10-160-NI	10	160	3	43	12	5	137
GN.26733	GN 425.3-12-125-NI	12	125	4	51	14	6	175
GN.26735	GN 425.3-12-160-NI	12	160	4	51	14	6	210
GN.26737	GN 425.3-12-200-NI	12	200	4	51	14	6	245
GN.26712	GN 425.3-16-125-NI	16	125	4	59	18	6	245
GN.26714	GN 425.3-16-160-NI	16	160	4	59	18	6	380
GN.26716	GN 425.3-16-200-NI	16	200	4	59	18	6	450
GN.26718	GN 425.3-20-200-NI	20	200	5	68	22	8	715
GN.26720	GN 425.3-20-250-NI	20	250	5	68	22	8	840